



TRIPLE CONGA STAND - LP291

ASSEMBLY INSTRUCTIONS

LP TRIPLE CONGA STAND (LP291) PARTS

- 1 Stand Bottom
- 1 Bottom Brace Tension Screw - LP913
- 1 Height Screw - LP914
- 3 Stand Top Mounting Brackets - LP291BR
- 1 Stand Top Tension Screw - LP307
- 3 Caster Wheels - LP910
- 3 Support Brackets - LP291SP
- 1 Stand Top - LP291ST

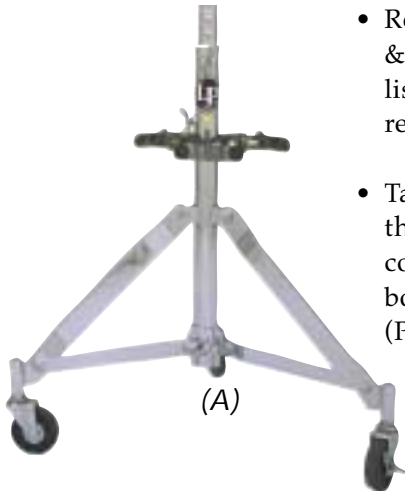

- Remove all items from box & compare with the above list to make sure you have received all the parts.
- Take Stand Bottom & unfold the legs until the brace collar rests flush with the bottom of the stand post. (Picture A)

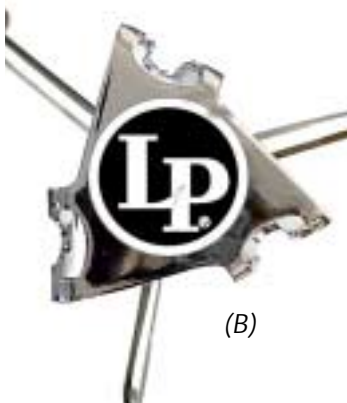
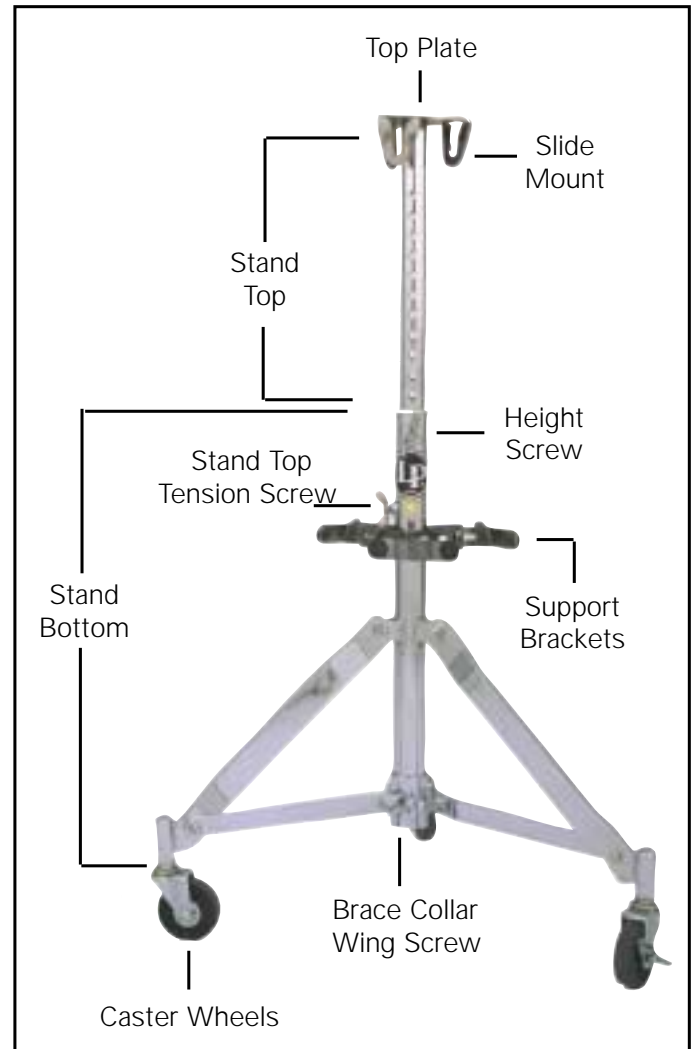

- Hand tighten the Brace Collar Wing Screw to lock the braces in place. Move Caster locks into place so the wheels are locked. Loosen the Stand Top Tension Screw and remove the Height Screw.

- Place the Stand Top into the Stand Bottom. Position Stand Top to desired height. Line up holes in Stand Top with holes in Stand Bottom. Re-insert Height Screw and hand tighten. Hand tighten Stand Top Tension Screw.

NOTE: View stand from above the Top Plate to make sure Conga Slide Mounts are lined up between the leg braces. (Picture B) If they are lined up directly on top of the leg braces remove the screws and rotate the Stand Top 180°. If the Stand Top is not positioned correctly the bottoms of the congas may hit the leg braces and not fit properly onto the stand.

* Top View of Stand Top



(C)

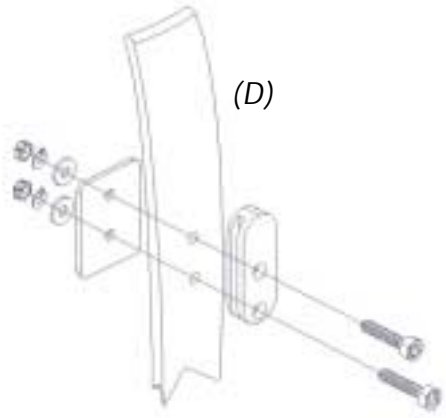

(D)

- Remove bracket bolts from your congas. Replace with Quick Mount Bracket provided. (Picture C)
- If you choose, you can raise one conga higher than the other two by attaching one mounting bracket upside down on the drum. (Picture D)



(E)

- Place one conga in the stand by guiding the Mounting Bracket into Slide Mount. (Picture E) This will let you determine where to place the Interlocking Conga Support Brackets.(Picture F) Remove the conga.
- Place the three Interlocking Conga Support Brackets on a flat surface. Make sure that the angled bumper section of each bracket is leaning toward the center at the top. Take the two brackets with hooks and fit them into the eyeholes of the third bracket. (Picture F)
- Wrap the three brackets around the area you determined previously. Take the provided bolt and insert it into the bracket with the square hole first then through the other bracket. Place the washer on the bolt and screw on wing nut until tight. (Picture F)
- Place the congas on the stand guiding each Mounting Bracket into a Slide Mount. Adjust Mounting Bracket in or out as necessary so they are flush against the shell of the congas. (Picture G)

(F)

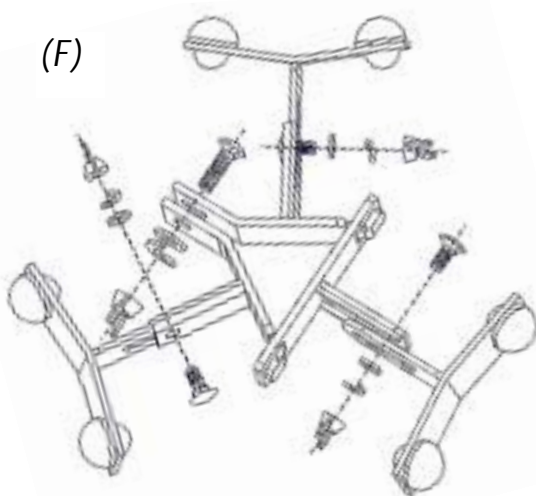

(G)

